

TURNKEY® Blade Shrouds Installation and Removal, TURNKEY® Rhino.

Assembly instructions

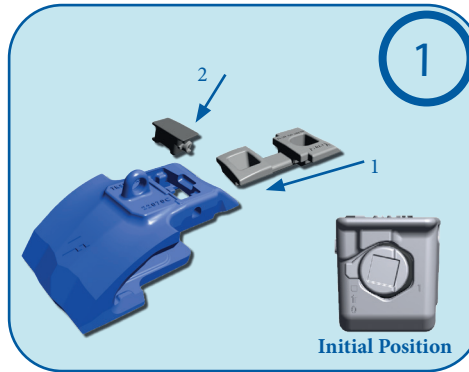

Equipment : Use the proper removal tool suitable for the TURNKEY® Shrouds size you will assembly .
Always work safely and wear your safety equipment (hard hat, steel-toed shoes, gloves, safety glasses).
Keep bystanders out of the way.



Pre-Assembling : Pre-assemble the 3 parts : Adapter, shroud and pin.

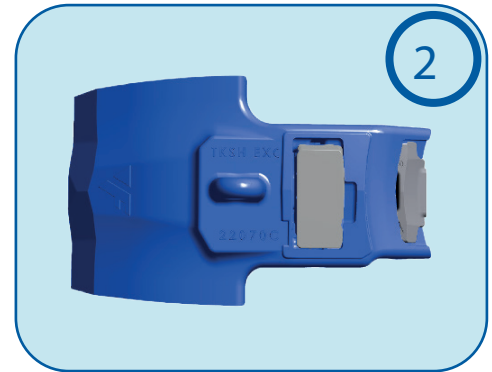

Correct assembly : Before installation on the blade, the shroud complete assembly should look like the above picture.

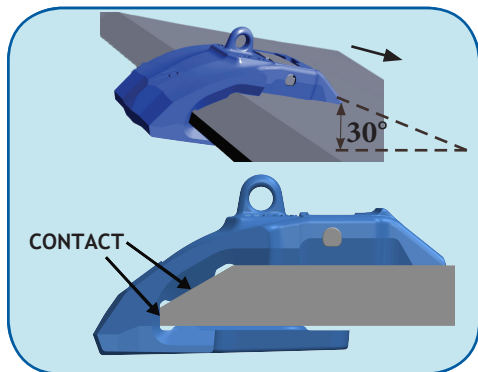

Adapter shroud positioning: Raise the blade edge to an angle of approximately 30°. Position the shroud assembly on the blade. Pull the adapter toward the center. Position adapter on blade, once the adapter is correctly located.

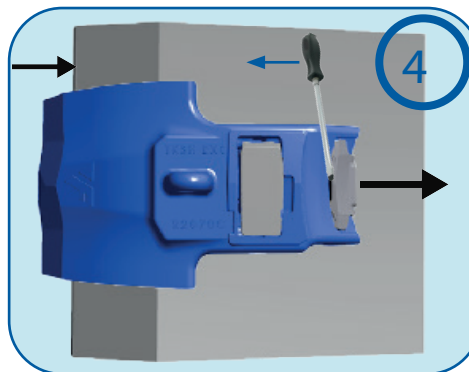

Welding instruction (step 1) : After having fixed the shroud adapter, please push the base towards the back of the bucket using a screw driver and please make 1 or 2 tacks welding spots to tack weld the adapter on the blade.
You'll complete welding after shroud removal.

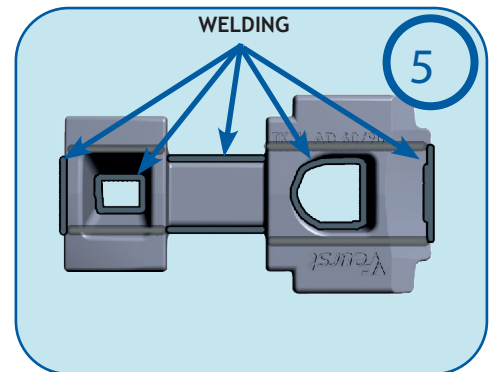

Welding instructions (step 2) : Once shroud adapter has been properly oriented and fixed by welding spots, remove pin and shroud. Heat the adapter at 175°-200°C and weld the areas indicated above.

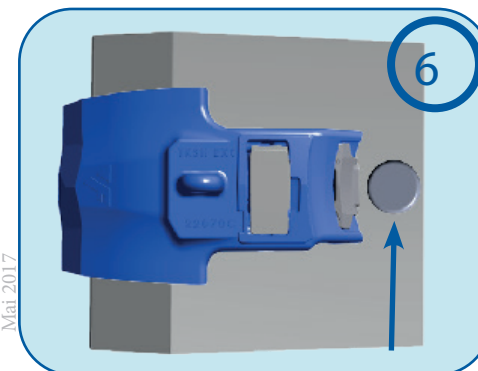

Welding instruction (step 3) : We highly recommend to weld a Wear Button on each shroud sides (see above picture).

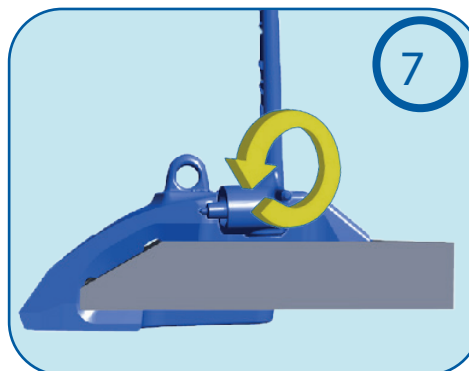

Pin clamping : Re-assemble the shroud and pin on the adapter
Once the pin has been correctly installed, take TK OD® tool to screw the pin. Make sure to screwing and then make a 180° counterclockwise pin turn. Once the pin rotation is fully completed, the pin cannot be turned any further.

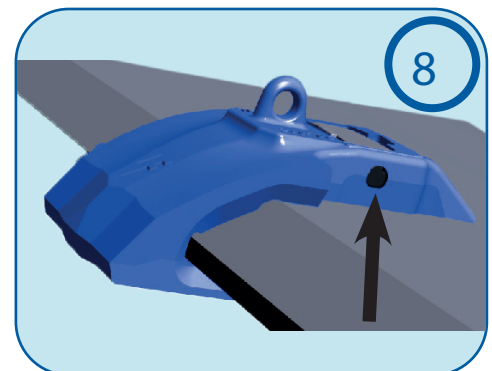

Protective caps installation : On both shrouds sides, insert the protective caps to avoid fines to fill up the pin hole.

TURNKEY® Shrouds Installation and Removal, TURNKEY® Range. ®.

Disassembly instructions



Equipment : A removal tool adapted to the size required to disassembly TURNKEY ® shrouds. Always work safely and wear your safety equipment (hard hat, steel-toed shoes, gloves, safety glasses).
Keep bystanders out of the way.

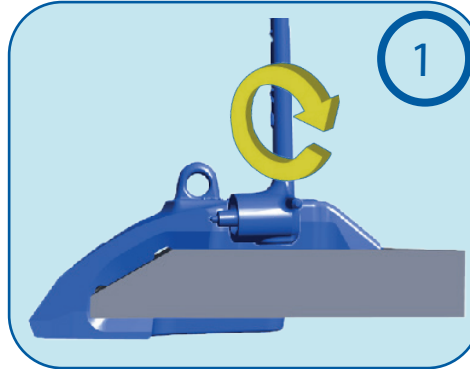

Pin unlocking : Remove the protective cap and insert the TK OD® tool into the pin, unlock the pin with a 180° clockwise turn.

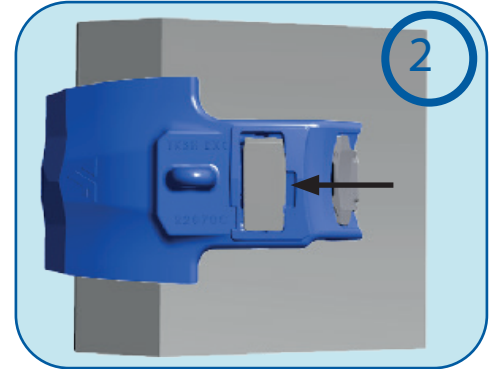

Pin removal : Using TK OD® tool, remove the pin from the shroud/sleeve. You can also remove the pin manually.

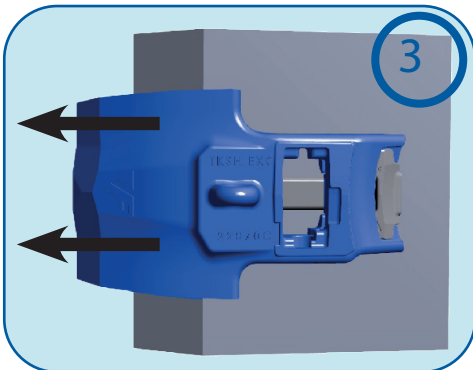

Shroud removal : Once the pin is removed, you can easily remove the shroud

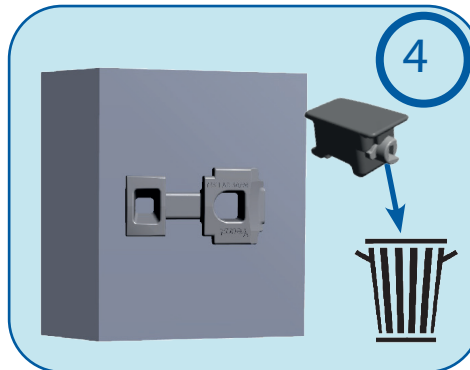

Shroud adapter cleaning : Clean up the shroud adapter and the pin housing. The adapter is ready to fitted with another new shroud.
We advise to use a new pin for next teeth installation.

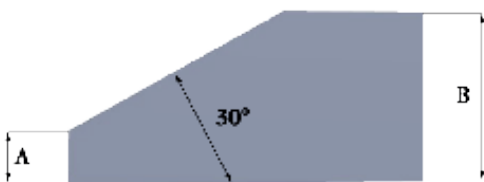

Blade Thickness	Chamfer Heel Thickness	Angle
60 mm	20 mm	30°
70 mm	21 mm	30°
80 mm	25 mm	30°
90 mm	28 mm	30°
100 mm	32 mm	30°
120 mm	43 mm	30°
140 mm	47 mm	30°