

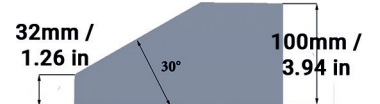

Bucket equipment
for quarrying & mining

TKN17 15100-A10°

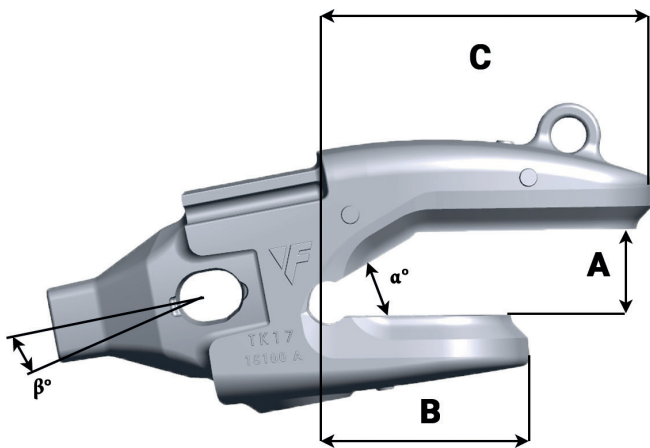
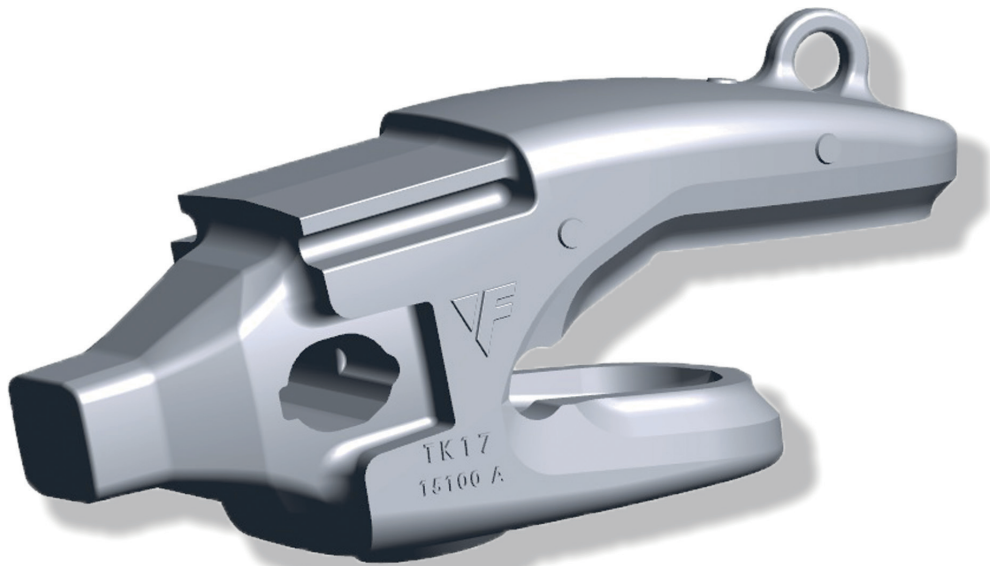

Référence Part number	Poids Weight Kg/Lbs	A mm/in	B mm/in	C mm/in	L mm/in	α°	β°
TKN17 15100- A10°	146 322	104 4.10	236 9.29	420 16.53	240 9.45	30°	10°

